

Vacuum Systems, Steam Jet Ejectors
& Atmospheric Air Ejectors

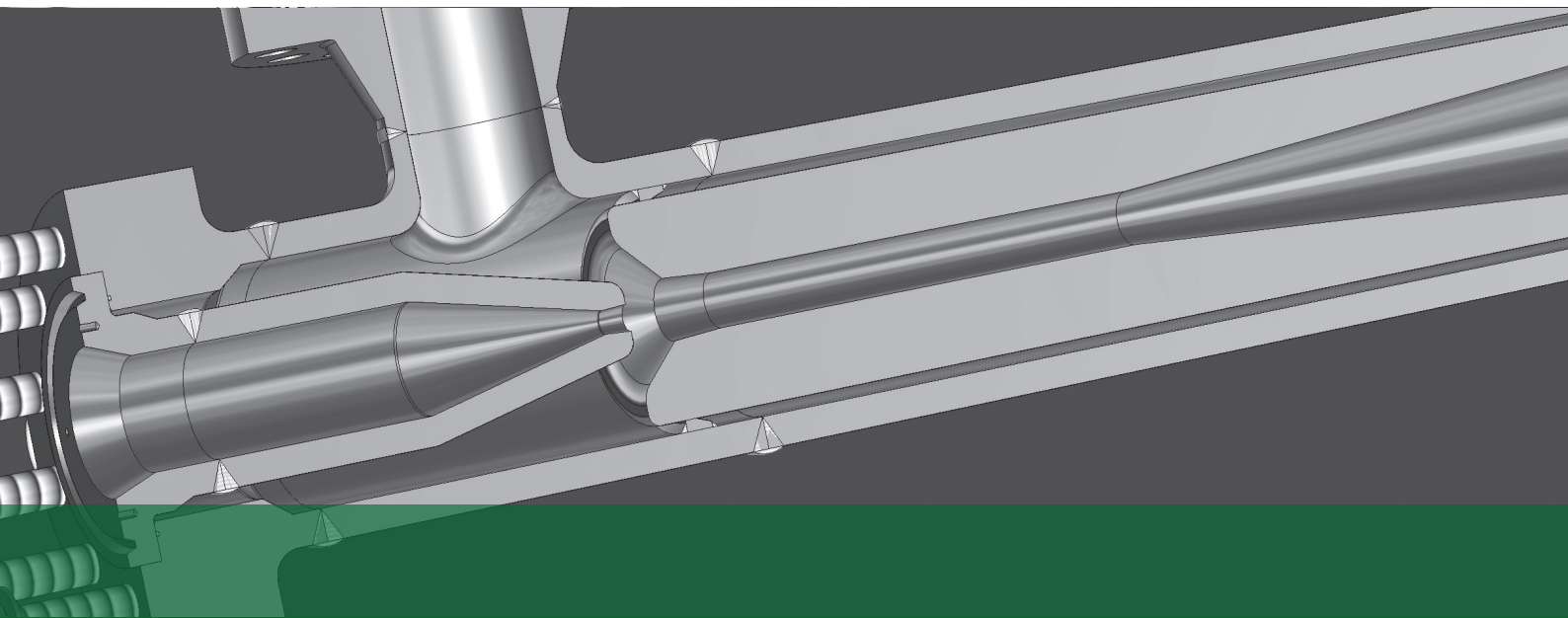



It's what we do.

Transvac has more than 40 years experience in the design and optimisation of Steam Jet Ejectors, Vacuum systems and Atmospheric Air Ejectors. This experience is invaluable because correct design can only be achieved using both empirical and theoretical considerations.

To ensure maximum efficiency with minimum capital costs all vacuum systems are custom designed to meet specific process requirements and transvac has many thousands of successful applications.

Meeting the high standards of quality, service and reliability demanded by the Chemical, Pharmaceutical and other industries, Transvac can offer Vacuum systems suitable for any industry.

All units are designed and manufactured to recognised codes of practice including *HEI, TEMA, ASME B31.3, BS 5500, STOOMWEZEN, AD MERKBLATTER* etc.

From small single units to fully packaged vacuum systems transvac's design and manufacturing processes are quality assured and certified to *BS EN ISO 9001 (Certificate No. FM 33189)*.

The qualified Chemical and Process Engineers at Transvac provide on-site support to assist with commissioning, troubleshooting and to advise on suitable equipment to uprate or replace existing vacuum systems.



Operating Levels

	Equipment	Applications
Positive +ve ↑ (Atmos) ↓ -ve Vacuum	760	Steam & Gas Pressure Boosting Sulphur Pit Ventilation Plot Area Limited
	100	Vacuum Pans & Evaporators for Foodstuffs Vacuum Cleaning, Filtering & Conveyance of Foodstuffs eg. Milk, Sugar, Salt. Vacuum Filtration of wet products Rapid evacuation of process vessels Medium range chemical reaction processes Refrigeration systems
Absolute Pressure mm Hg (Torr)	10	Vacuum deaeration of semi-solids eg. Clay Vacuum distillation & crystallisation Air removal from process plant such as:- Chemical distillation units Steam condensers Evaporators Chemical reaction vessels
	2	Vacuum cooling Vacuum stripping & deodorizing units for animal and vegetable oils Vacuum crystallisation Water vapour refrigeration units Vacuum drying Vacuum packing for perishable foodstuffs Vacuum distillation
0.4	Four Stage Steam Ejectors	Vacuum distillation
	Two Stage Steam Ejectors/ Two Stage Liquid Ring Pump	Freeze drying & dehydration units for sublimation drying of foods, drugs etc.
	Five Stage Steam Ejectors Three Stage Steam Ejectors/ Two Stage Liquid Ring Pump	As for four-stage systems but at higher vacuums



Standard Range

Transvac design and manufacture a comprehensive range of Steam Jet Ejectors from coarse vacuum single stage units; such as rapid evacuation ejectors (Hoggers) up to 5 stage Steam Jet Ejector Systems fully packaged to produce vacuum levels of up to 25 microns Hg abs.

Modern, energy efficient Steam Jet Ejector Systems offer many advantages when compared with other vacuum producing systems. They can also utilise motive steam which is already available on site and would otherwise be wasted.

Advantages

- ▶ The most reliable of all high vacuum systems
- ▶ Ideal for large loads
- ▶ No moving parts
- ▶ Simplicity
- ▶ Low noise levels
- ▶ Minimal and non-specialist maintenance
- ▶ Custom designed
- ▶ Easy to retrofit or uprate
- ▶ Process guaranteed
- ▶ Available in any workable material



Steam Ejector for distillation process

Materials of Construction

For non-corrosive applications stainless steel or carbon steel are most commonly used.

Condensers

Direct Contact and Indirect Contact Condensers are available for either barometric or low level operation. Indirect or Surface Contact Condensers are used when the Ejector fluid and cooling medium must be kept separate, whereas Direct Contact Condensers are used when mixing of fluids is acceptable.

Corrosion Resistant Range

Transvac has considerable experience in supplying corrosion resistant Vacuum Systems. They are ideal for Fine Chemical and Pharmaceutical applications by virtue of their reliability, simplicity, low capital cost and low maintenance requirements.

Advantages

- ▶ Handles large volumes of gas
- ▶ The most reliable of all high integrity vacuum systems
- ▶ Handles slugs of liquid/particles without damage
- ▶ No moving parts
- ▶ Low noise levels
- ▶ Less expensive than Mechanical Pumps
- ▶ Simplicity and low maintenance
- ▶ Custom designed for high or low vacuums
- ▶ Easy to retrofit or uprate
- ▶ Overheating not a problem

Materials of Construction

Steam Jet Ejectors can be constructed from exotic materials including PTFE, PVDF, hastelloy, graphite, monel, etc.

Indirect Contact Condensers are usually constructed from graphite and titanium and Direct Contact Condensers from PTFE lined carbon steel or PVDF.

Condensers

Direct Contact and Indirect Contact Condensers are available for either barometric or low level operation.



Hastelloy Ejector for sulphuric acid processing



Titanium Steam Ejector for chemical Reactor

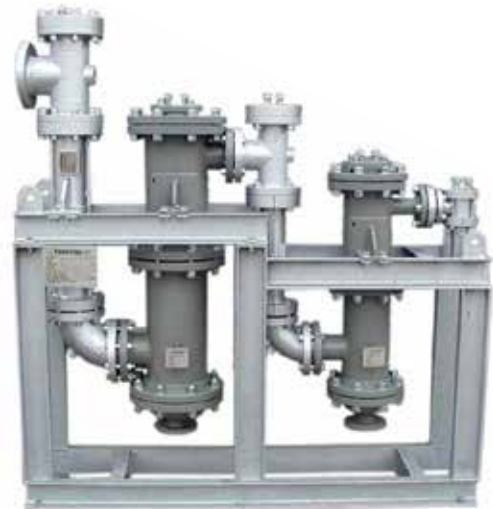

PTFE multi-stage Ejector Set for pharmaceutical plant



Four Stage Corrosion resistant Steam Jet Ejector System.
PTFE Ejectors and Graphite Block Condensers



Steam Jet Ejector & Liquid Ring Vacuum Pump Systems

Transvac offer a complete range of fully instrumented low level skid mounted systems, versatile in handling both wet and dry loads. Designed to user specifications and offering clear energy savings.

Systems are available with one, two or three stages of Steam Jet Ejectors combined with a single or two stage Liquid Ring Vacuum Pump. The Liquid Ring Pump is very effective at rapidly producing a coarse vacuum and the Steam Jet Ejectors are used to create higher vacuum levels.

- ▶ Reliable with only one moving part
- ▶ Energy efficient
- ▶ Operates with very low steam pressures
- ▶ Low level operation
- ▶ Simplicity
- ▶ Low noise levels
- ▶ Custom designed
- ▶ Easy to retrofit or uprate

Atmospheric Air Jet Ejector & Liquid Ring Vacuum Pump Systems

Transvac manufactures a comprehensive range of Atmospheric Air Jet Ejectors used to extend the operating range of Liquid Ring Vacuum Pumps.

The inlet pressure of a Liquid Ring Pump is limited to approximately 30 mbar abs because of the vapour pressure of its seal liquid (usually water). The addition of an Atmospheric Air Jet Ejector enables the Liquid Ring Vacuum Pump to operate outside its cavitation range allowing operation down to nearly 4 mbar abs.

Transvac Atmospheric Air Jet Ejectors can be combined with Liquid Ring Vacuum Pumps to increase their ultimate vacuum levels.

- ▶ No additional energy source needed (atmospheric air)
- ▶ Reliable
- ▶ Ideal for retrofitting on small load duties



ATMOSPHERIC AIR JET EJECTOR
IN STAINLESS STEEL



ATMOSPHERIC AIR JET EJECTOR
IN CARBON STEEL

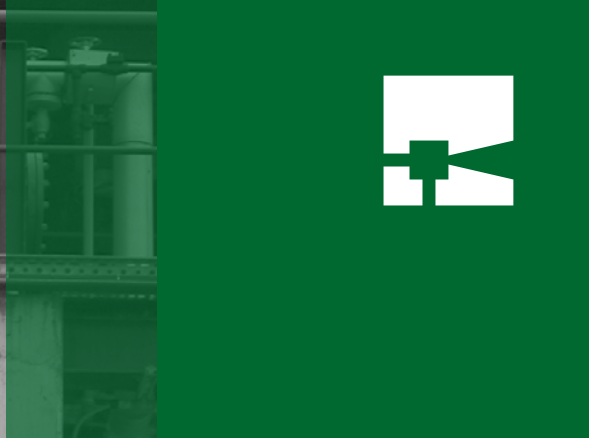

Performance

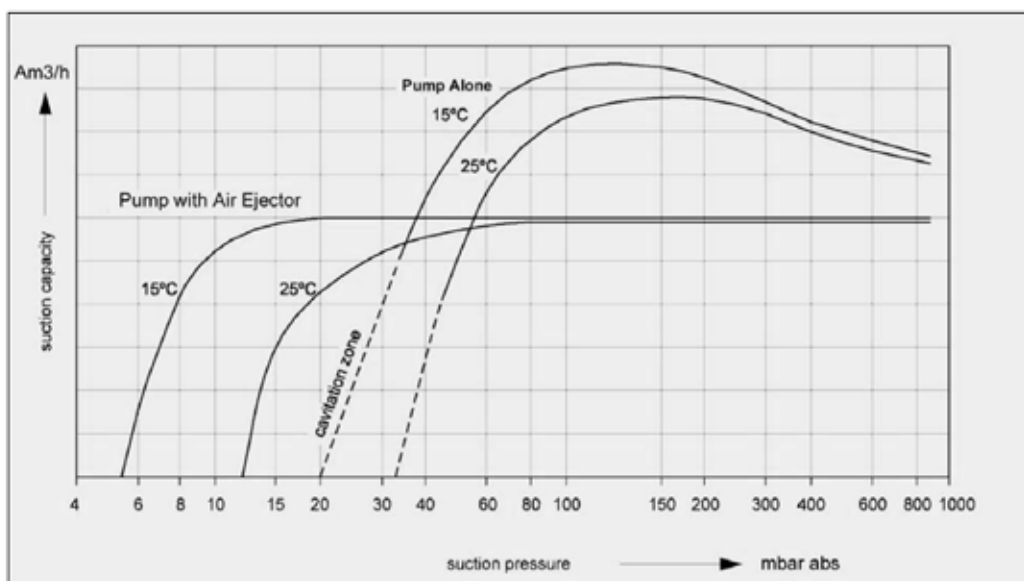

The chart above shows the typical performance of a 2 stage Liquid Ring Pump operating alone with seal water at temperatures of 150C and 250C and when operating in combination with an Atmospheric Air Jet Ejector. A by-pass line can be installed around the Ejector when evacuation times are critical. All Transvac Ejectors are custom designed to suit each application to ensure maximum operating efficiency.

Construction

Standard materials of construction include Carbon Steel, Stainless Steel, Polypropylene, PTFE and Titanium. Other materials are also available. Connections can be flanged or screwed. All of Transvac's design and manufacturing processes are designed to the latest European standards and quality assured and certified to BS EN ISO 9001:2015. Units are CE marked where applicable.

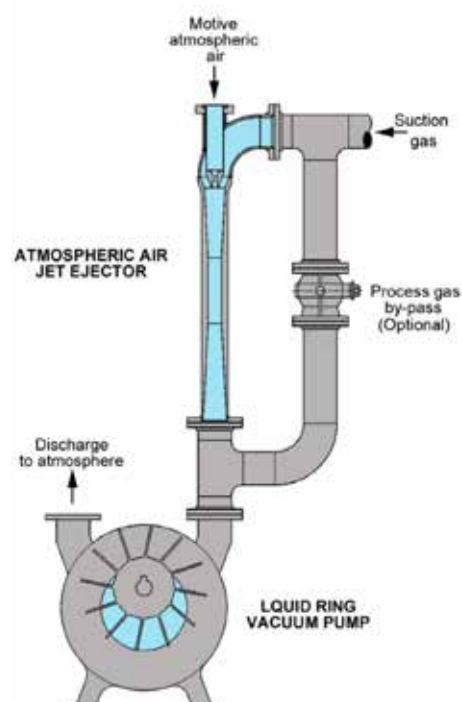



Liquid Jet Exhauster Systems

For batch plant applications requiring coarse vacuum and low level installation.

With the liquid recirculating pump being the only moving part the Liquid Jet Exhauster System is simple to maintain and very reliable to operate.

The ability to produce vacuum and simultaneously scrub entrained gases before discharge to atmosphere makes this system ideal for contaminated and/or corrosive applications. Available in multi-element form as a central vacuum source on multi-purpose process applications.

Advantages

- ▶ Reliable with only one moving part
- ▶ Scrubs outlet gases
- ▶ Handles liquids/particles without damage
- ▶ Energy efficient
- ▶ Low level operation
- ▶ Simplicity
- ▶ Low noise levels
- ▶ Custom designed
- ▶ Materials to suit process fluid

Other steam or gas jet applications

- ▶ Gas compression
- ▶ Steam thermocompressors
- ▶ Sulphur pit ventilation
- ▶ Bund emptying
- ▶ Gas ventilation
- ▶ Vacuum transfer
- ▶ Gas dilution
- ▶ Gas/liquid sampling



“ we are focused on turning innovative designs into proven solutions.

- Gary Short, R&D Director



R&D Test Facility

Transvac officially opened its R&D Test facility in April 2010. The state-of-the-art test facility primarily develops new oil & gas Ejector technology for subsea processing, flare gas recovery, sand slurry pumping and enhanced recovery & production solutions.

Ejector applications for the nuclear, bio-fuel, chemical and wastewater industries are also under development.

The R&D test facility includes high and low pressure equipment for handling water, oil, gas, multi-phase and slurry. Test programmes are supported by CFD studies and include fundamental University research.

The Transvac facilities include liquid flow lines for high, medium & low pressure testing (in excess of 250 barg) and solids handling systems.

The FlareJet zero-flare solution was developed here, offering gas compression of up to 150:1 with a liquid driven Ejector.

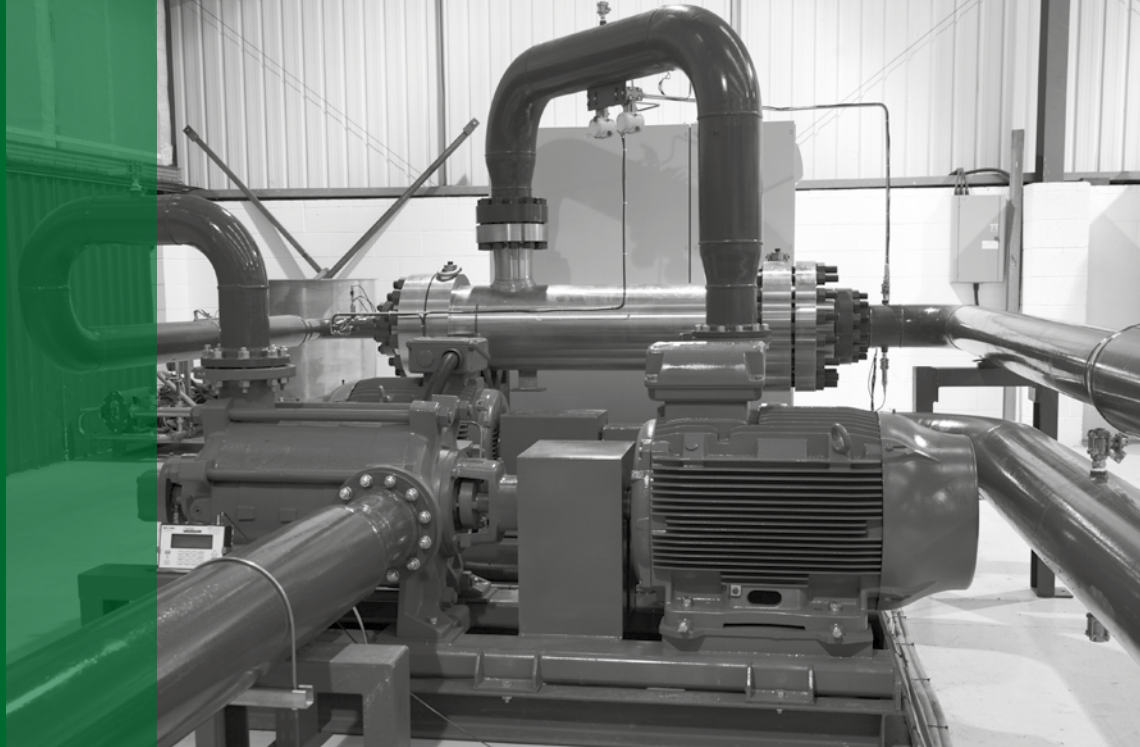

Test Facilities

- ▶ 8 x flow loops
- ▶ 8 x VSD water pumps
- ▶ Pump pressure up to 300 bar
- ▶ Liquid flows up to 700 m³/h
- ▶ Sand slurry flows up to 60 m³/h (up to 60% SVF)
- ▶ Nitrogen 100barg @ 200 kg/h
- ▶ Air 12.5 barg @ 70 Am³/h
- ▶ 400 KvA stand alone generator
- ▶ 150 KvA mains supply
- ▶ 2 x 9 m³ clean water tanks
- ▶ 1 x 35 m³ slurry / water tank
- ▶ 1 x 6 m³ calibrated weigh tank
- ▶ 5 x coriolis meters (liquid / gas)
- ▶ 1 x 16m³ 27.5 barg pressure vessel for closed loop multi-phase testing
- ▶ High pressure in-line solids / phase separator (150 barg and 100 m³/h)
- ▶ Fully automatic control and data acquisition system using ASi field bus system (LabView)
- ▶ Flow assurance : flow accuracy 0.1 - <1.0 % FS / Pressure Accuracy 0.1% or better

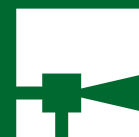

About Us

Transvac Systems Limited is a privately owned Ejector Solutions provider formed in 1973.

As both a designer and a manufacturer of Ejectors, Transvac has full in-house control over process and mechanical design, supply of raw materials, manufacturing, scheduling and testing. With all of our procedures certified to BS EN ISO 9001:2015 the quality of the final product is assured.

Transvac is accredited to Module H of the Pressure Equipment Directive (PED) and our products are CE marked where appropriate. We are also 1st Point Assessment (FPAL) and Achilles registered.

All products are custom designed to suit the process and mechanical requirements of each application to ensure maximum operating efficiency.

Transvac offers standard and exotic materials of construction including Hastelloy, Duplex, Super Duplex, Titanium, 6MO etc.



Contact Us

Transvac Systems Ltd. Monsal House, 1 Bramble Way, Alfreton, Derbyshire, DE55 4RH, UK

Tel: +44 (0) 1773 831100 | **Email:** sales@transvac.co.uk | **Web:** www.transvac.co.uk

