

Universal Design Ejectors

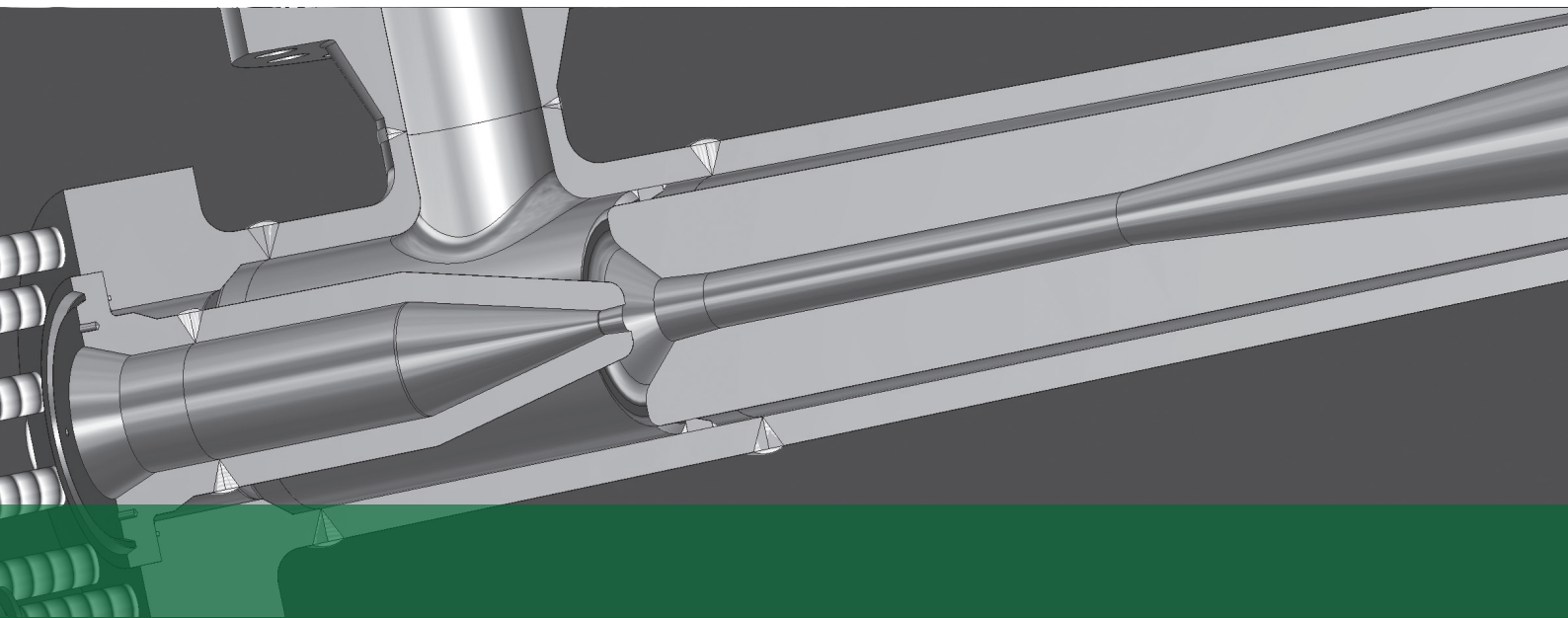



'Universal Design' Ejectors

We understand that production is not always predictable. Conditions change over time and facilities need to be able to deal with this.

Ejectors are fixed-design devices. Each of our Ejectors are custom designed to perform at specific operating conditions. That's why we invented our patented 'Universal Design' Ejector.

The patented Universal Design (UD) comprises an external pressure retaining shell into which are fitted two replaceable components which give the Ejector its operating characteristics. These two components are called the nozzle and the diffuser and in the Universal Design, they can be easily changed-out with different ones in order to give the Ejector different optimum operating characteristics.

Thus, as process conditions change over time, the internals can be replaced with new ones which are more suited to the changed conditions.

By changing-out the internals at recommended intervals, high performance efficiency can be maintained over the lifetime of the unit, thereby maximising gas recovery.



'Universal Design' nozzle and diffuser sections designed to allow the Ejector to operate at new production conditions



Why choose Universal Design?

- ▶ For instances where operating conditions may change gradually over time (e.g. declining well conditions)
- ▶ UD pressure retaining shell can be sized to suit future operating conditions
- ▶ UD nozzle and diffuser internals easily changed-out to suit different operating conditions
- ▶ UD pressure retaining shell can be manufactured before operating conditions have been confirmed
- ▶ Manufacture of UD nozzle & diffuser can be delayed until the last few weeks of contract, when operating conditions are confirmed (e.g. when a new well is completed)
- ▶ Change-out of the new UD internals can be completed in one day
- ▶ Less risk to project if predicted operating conditions are found to be wrong, because new internals can be made relatively quickly and with no changes to associated pipework
- ▶ Easier to realise short-term well opportunities with UD design approach
- ▶ Without internals fitted, pressure retaining shell simply behaves as a piece of pipework
- ▶ Potential to relocate UD to a new site with different operating conditions and different internals

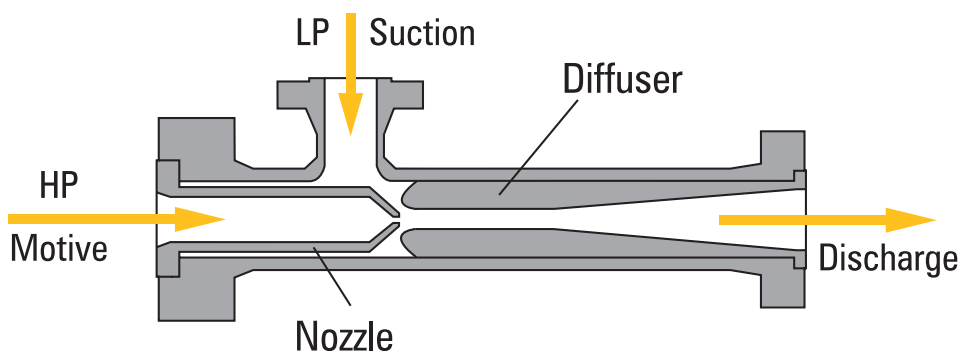

Contact Us

Transvac Systems Ltd. Monsal House, 1 Bramble Way, Alfreton, Derbyshire, DE55 4RH, UK

Tel: +44 (0) 1773 831100 | **Email:** sales@transvac.co.uk | **Web:** www.transvac.co.uk

