

Liquid Jet Solids Pumps

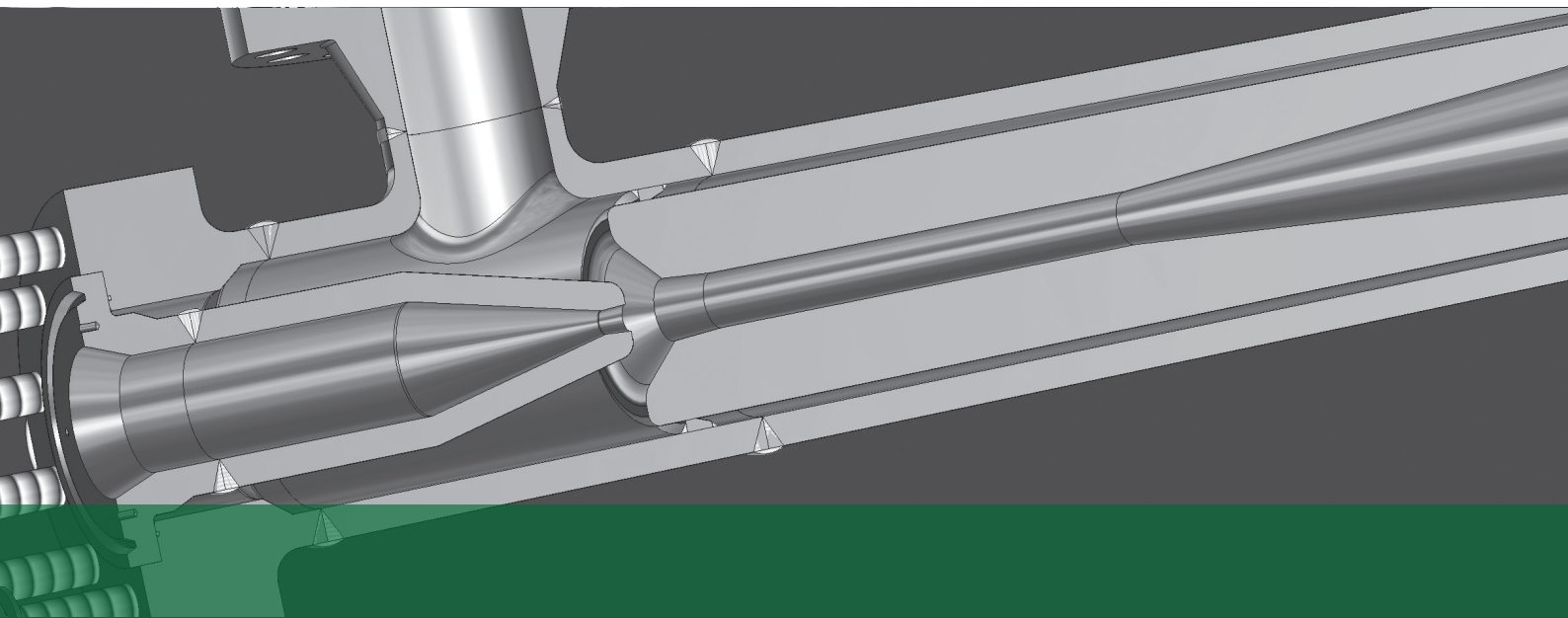

Liquid Jet Solids Pumps

Transvac Liquid Jet Solids Pumps provide a versatile method of entraining solids, mixing them with the motive liquid and pumping the resulting mixture.



Configurations:

- Once-through or batch operation
- Standard or hygienic finish
- Mobile
- Fixed on a skid
- Packaged system
- Containerised system
- Manually fed from sacks
- Screw fed from a Bulk Bag system
- Screw fed from a Silo

Typical Applications:

Water Treatment

- Powdered activated carbon - 1
- Granular activated carbon
- Ion Exchange resin - 2
- Sand filtrate - 3

Food / Pharmaceutical

- Alginates
- Starches
- Salt - 4
- Sugar / dextrose - 5
- C.M.C.
- Citric acid granules
- Milk powder

Chemical / Other

- Pulverised fly ash - 6
- Salt
- Dye powders - 7
- Barium carbonate
- Magnesium oxide
- Lime - 8

Advantages:

- No moving parts
- Simple & robust
- Custom designed
- Suitable for CIP
- Solids added at ground level
- In-line mixing

Materials:

- Carbon steel
- Stainless steel
- PVCu / PP
- Ceramic

Quality Assurance:

Transvac are accredited to ISO 9001:2015 and certified to module H of the PED.

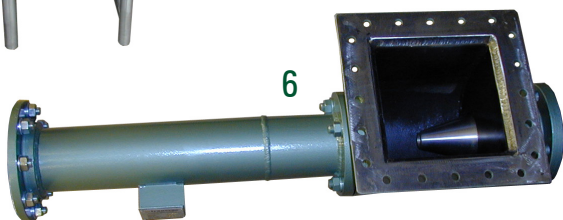
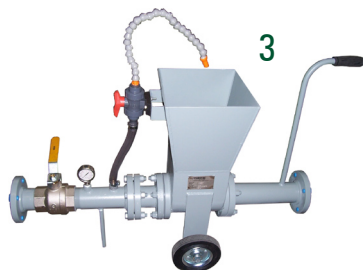

Contact Us

Transvac Systems Ltd. Monsal House, 1 Bramble Way, Alfreton, Derbyshire, DE55 4RH, UK

Tel: +44 (0) 1773 831100 | **Email:** sales@transvac.co.uk | **Web:** www.transvac.co.uk

