

Liquid Jet Pumps

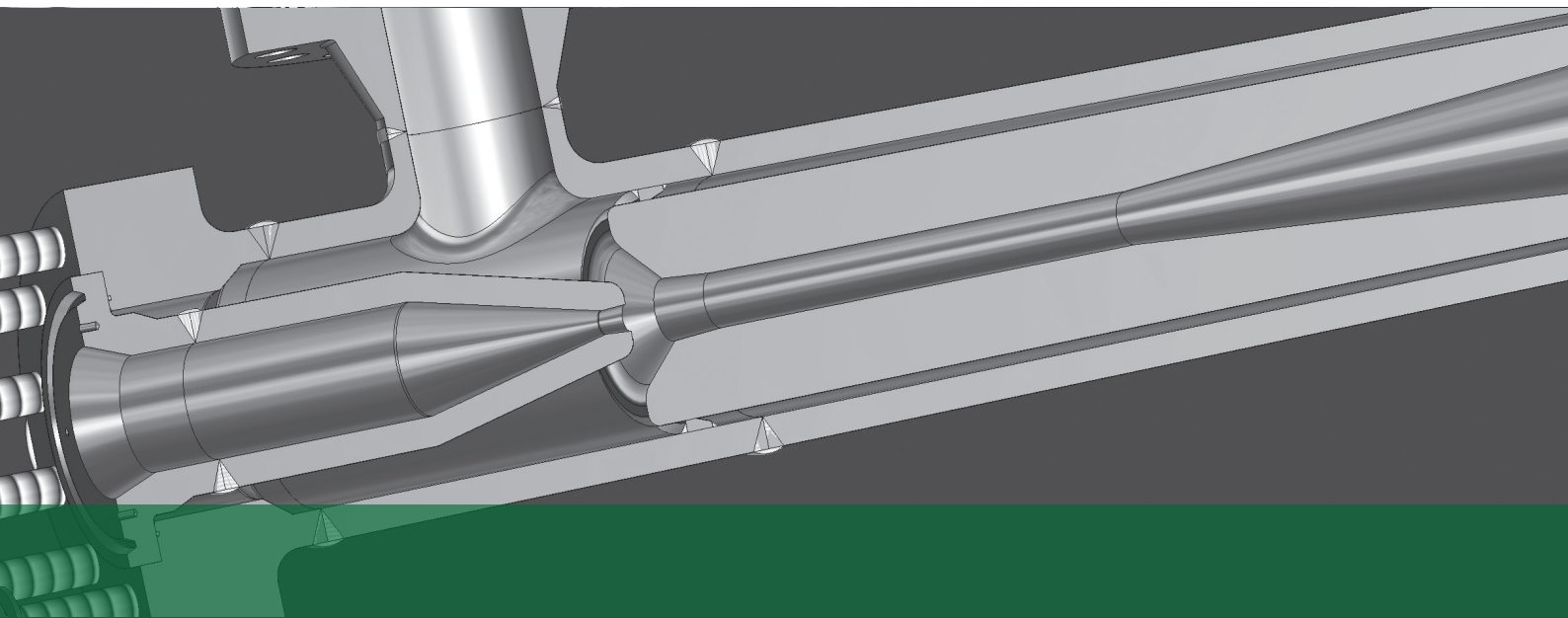

Liquid Jet Pumps

Transvac has been manufacturing Liquid Jet Pumps for the process industries for over 43 years. From complete packaged systems to single units, all Transvac's products are custom designed to meet the client's specific requirements.

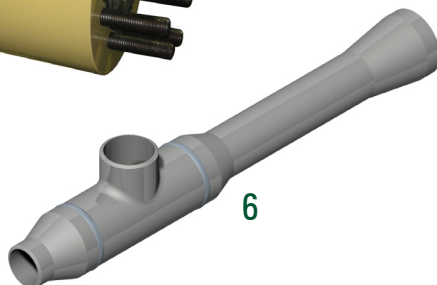
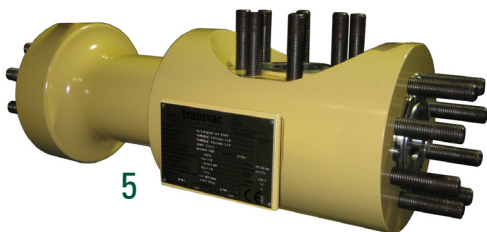
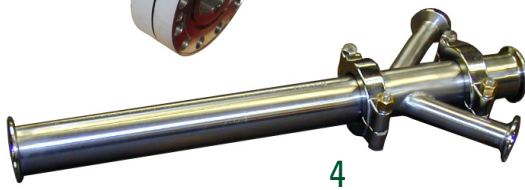

Typical Applications:

- Acid dilution on water treatment works (PVCu internals and steel support shell) - **1**
- Acid / caustic dosing system for power station water treatment plant - **2**
- Pumping abrasive slurry for subsea processing (ceramic internals) - **3**
- Acid & caustic dilution as part of a CIP system (hygienic design) - **4**
- High pressure oil & gas test plant (duplex) - **5**
- Nuclear waste transfer - **6**

Advantages:

- No moving parts
- Simple to install and operate
- Low cost with short payback
- No ATEX problems
- Negligible maintenance
- Proven reliability

Typical Materials:

- Carbon Steel
- 316L Stainless Steel
- PTFE
- uPVC
- PP
- Duplex / Super Duplex
- Hastelloy

Design Standards / Codes:

- ASME B31.3
- PD 5500
- ASME VIII

Quality Assurance :

Transvac are accredited ISO 9001:2015 and certified to module H of the PED

Contact Us

Transvac Systems Ltd. Monsal House, 1 Bramble Way, Alfreton, Derbyshire, DE55 4RH, UK

Tel: +44 (0) 1773 831100 | **Email:** sales@transvac.co.uk | **Web:** www.transvac.co.uk

